

Unofficial Text (See Printed Volume). Current through date and Register shown on Title Page.

Chapter Comm 69

BARRIER-FREE DESIGN

Subchapter I — Administration and Enforcement

Part 1—Purpose and Scope

- Comm 69.01 Purpose.
Comm 69.02 Scope.

Part 2—Application of Code

- Comm 69.03 Application.
Comm 69.04 Buildings exempt from the code requirements.
Comm 69.045 Maintenance of facilities.

Part 3—Design and Supervision

- Comm 69.05 Design and supervision.

Part 4—Departmental Action

- Comm 69.06 Plan examination and department action.

Part 5—Enforcement, Appeals, Petitions for Variance and Penalties

- Comm 69.07 Enforcement.
Comm 69.08 Appeals.
Comm 69.09 Penalties.
Comm 69.10 Petitions for variance.

Part 6—Adoption of Standards

- Comm 69.105 Adoption of standards.

Subchapter II — Standards for New Construction, Additions and Alterations

Part 1—ADAAG Standards

- Comm 69.11 Standards for new construction, additions and alterations.

Part 2—Changes or Additions to or Omissions from the ADAAG Standards

- Comm 69.12 Changes or additions to or omissions from the ADAAG.

Subpart 1—Purpose

- Comm 69.13 Purpose [ADAAG 1.0].

Subpart 2—General

- Comm 69.14 Equivalent facilitation [ADAAG 2.2].

Subpart 3—Miscellaneous Instructions and Definitions

- Comm 69.15 Miscellaneous instructions and definitions [ADAAG 3.0].

Subpart 4—Accessible Elements and Spaces: Scope and Technical Requirements

- Comm 69.16 Applications [ADAAG 4.1.1].
Comm 69.17 Accessible elements and spaces: scope and technical requirements [ADAAG 4.1.2].
Comm 69.18 Accessible buildings: new construction requirements [ADAAG 4.1.3].
Comm 69.19 Accessible building: additions [ADAAG 4.1.5].

- Comm 69.20 Accessible buildings: alterations [ADAAG 4.1.6].
Comm 69.21 Accessible buildings: historic [ADAAG 4.1.7].
Comm 69.22 Wheelchair passage width [ADAAG 4.2.1].
Comm 69.23 Accessible route [ADAAG 4.3].
Comm 69.24 Protruding objects [ADAAG 4.4.1].
Comm 69.245 Parking spaces [ADAAG 4.6.3].
Comm 69.25 Curb ramps [ADAAG 4.7].
Comm 69.26 Ramps [ADAAG 4.8].
Comm 69.27 Stairs [ADAAG 4.9].
Comm 69.275 Elevators [ADAAG 4.10].
Comm 69.28 Platform lifts [ADAAG 4.11].
Comm 69.29 Doors [ADAAG 4.13].
Comm 69.30 Toilet stalls [ADAAG 4.17].
Comm 69.32 Faucets [ADAAG 4.19.5].
Comm 69.34 Shower stalls [ADAAG 4.21].
Comm 69.35 Toilet rooms, clear floor space [ADAAG 4.22.3].
Comm 69.36 Size and spacing of grab bars and handrails [ADAAG 4.26.2].
Comm 69.37 Detectable warnings on walking surfaces [ADAAG 4.29.2].
Comm 69.375 Assembly seating [ADAAG 4.33.3].
Comm 69.39 Dressing and fitting rooms [ADAAG 4.35].

Subpart 5—Restaurants and Cafeterias

- Comm 69.40 Restaurants and cafeterias [ADAAG 5.0].

Subpart 6—Medical Care Facilities

- Comm 69.41 Medical care facilities [ADAAG 6.0].

Subpart 7—Business and Mercantile

- Comm 69.415 General [ADAAG 7.1].

Subpart 8—Libraries

Subpart 9—Accessible Transient Lodging

- Comm 69.42 Accessible transient lodging [ADAAG 9.0].

Subpart 10—Transportation Facilities

Subpart 11—Judicial, Legislative, and Regulatory Facilities

- Comm 69.45 General.

Subpart 12—Detention and Correctional Facilities

- Comm 69.46 General.
Comm 69.47 Entrances.
Comm 69.48 Residential cells or rooms: minimum number.
Comm 69.49 Requirements for accessible residential cells or rooms.
Comm 69.50 Visual alarms and telephones.

Note: Chapter Comm 69 has been repealed effective July 1, 2002. Please see Chs. Comm 61 to 65, Wisconsin Commercial Building Code for rules that regulate the subject matter of ch. Comm 69.

Note: Chapter ILHR 69 was renumbered to be chapter Comm 69 under s. 13.93 (2m) (b) 1. and corrections were made under s. 13.93 (2m) (b) 7., Stats., Register, December, 1997, No. 504. Corrections made under s. 13.93 (2m) (b) 7., Stats., Register, December, 1998, No. 516.

Subchapter I — Administration and Enforcement

Part 1—Purpose and Scope

Comm 69.01 Purpose. The purpose of this chapter is to insure that any building or facility is designed, constructed, and altered to be accessible and usable by people with disabilities.

History: Cr. Register, November, 1994, No. 467, eff. 12-1-94.

Comm 69.02 Scope. Except as specified in s. Comm 69.04, this chapter applies to all buildings and facilities. The requirements of this chapter are not retroactive unless specifically stated in the administrative rule. Where different sections of this chapter specify different requirements, the most restrictive requirement shall govern. This chapter is not intended to prohibit or discourage the design and construction of innovative buildings or the use of new materials or systems provided written approval from the department is obtained. Under this chapter, written approval from the department shall include, but is not limited to, an acceptance through preliminary design consultation, plan review, petition for variance, official code interpretation, material approval or other forms of written communication.

History: Cr. Register, November, 1994, No. 467, eff. 12-1-94.

Part 2—Application of Code

Comm 69.03 Application. (1) NEW CONSTRUCTION AND ADDITIONS. All new construction and additions shall comply with this chapter.

(2) ALTERATIONS TO BUILDINGS. Any remodeling or alterations, or both, in a building or facility which affects or could affect the usability of or access to a building or facility by a person with a disability shall comply with this chapter.

(3) CHANGE OF USE. The requirements of this chapter shall be applied when the use of an existing building or facility is changed and the building or facility is altered or remodeled in accordance with s. Comm 69.20 and ADAAG 4.1.6.

Note: The federal Americans with Disabilities Act (ADA) requires public accommodations to remove architectural barriers in existing buildings where the removal of such barriers is readily achievable. See 28 CFR Part s. 36.304.

History: Cr. Register, November, 1994, No. 467, eff. 12-1-94; r. and recr. (3), Register, December, 1997, No. 504, eff. 1-1-98.

Comm 69.04 Buildings exempt from the code requirements. This chapter does not apply to buildings specified in s. Comm 50.04.

History: Cr. Register, November, 1994, No. 467, eff. 12-1-94.

Comm 69.045 Maintenance of facilities. Any building, facility or site which is constructed or altered to be accessible under this chapter shall be maintained accessible during its occupancy.

History: Cr. Register, December, 1997, No. 504, eff. 1-1-98.

Unofficial Text (See Printed Volume). Current through date and Register shown on Title Page.

Part 3—Design and Supervision

Comm 69.05 Design and supervision. The design and construction supervision of a building or facility shall comply with ss. Comm 50.07 to 50.11.

History: Cr. Register, November, 1994, No. 467, eff. 12-1-94.

Part 4—Departmental Action

Comm 69.06 Plan examination and department action. (1) ALL BUILDINGS. The accessibility requirements of this chapter shall be presented as part of the general plan submittals required under s. Comm 50.12 (2) and (3). The requirements of ss. Comm 50.12, 50.13 to 50.175, 50.18 (1) and 50.20 shall be complied with where applicable to the project.

(2) ADDITIONS AND ALTERATIONS. Plans and specifications showing compliance with this chapter and the primary path of travel to the added or altered area shall be submitted to the department or its authorized representative for department action.

History: Cr. Register, November, 1994, No. 467, eff. 12-1-94; am. (1), Register, December, 1997, No. 504, eff. 1-1-98.

Part 5—Enforcement, Appeals, Petitions for Variance and Penalties

Comm 69.07 Enforcement. This chapter shall be enforced by the department or by municipal officials or other local officials who are required by law to enforce the administrative rules of the department. The department shall have the responsibility for interpreting the rules in this chapter, including the Americans with Disabilities Act Accessibility Guidelines (ADAAG) incorporated as department standards.

History: Cr. Register, November, 1994, No. 467, eff. 12-1-94.

Comm 69.08 Appeals. Any person affected by any local order which is in conflict with a rule of the department may petition the department for a hearing on the grounds that the local order is unreasonable and in conflict with the rule of the department. The department shall review and make a determination on an appeal of a local ordinance within 60 business days of receipt of a verified petition submitted with all forms, fees, plans and documents required to complete the review.

Note: Section 101.01 (1) (g), Stats., defines "local order" as any ordinance, order, rule or determination of any common council, board of alders, board of trustees or the village board, of any village or city, or the board of health of any municipality, or an order or direction of any official of such municipality, upon any matter over which the department has jurisdiction.

Note: This chapter does not invalidate or limit the remedies, rights and procedures of federal laws, or local laws that provide greater or equal protection for the rights of individuals with disabilities or individuals associated with them.

History: Cr. Register, November, 1994, No. 467, eff. 12-1-94.

Comm 69.09 Penalties. Penalties for violations to this chapter shall be assessed in accordance with s. 101.02 (13) (a), Stats.

Note: Section 101.02 (13) (a), Stats., indicates penalties will be assessed against any employer, employee, owner or other person who fails or refuses to perform any duty lawfully enjoined, within the time prescribed by the department, for which no penalty has been specifically provided, or who fails, neglects or refuses to comply with any lawful order made by the department, or any judgment or decree made by any court in connection with ss. 101.01 to 101.25, Stats. For each such violation, failure or refusal, such employee, owner or other person must forfeit and pay into the state treasury a sum not less than \$10 nor more than \$100 for each violation.

Note: Section 101.02 (12), Stats., indicates that every day during which any person, persons, corporation or any officer, agent or employee thereof, fails to observe and comply with an order of the department will constitute a separate and distinct violation of such order.

History: Cr. Register, November, 1994, No. 467, eff. 12-1-94.

Comm 69.10 Petitions for variance. (1) PROCEDURE. The department shall consider and may grant a variance to an administrative rule under this chapter upon receipt of a fee, a completed petition for variance form from the owner, and a position statement from the fire department and the certified municipality having responsibility and an interest in the rule, provided an equivalency is established in the petition for variance which meets

the intent of the rule being petitioned. The department may impose specific conditions in a petition for variance to promote the protection of the health, safety or welfare of the employees or the public. Violation of those conditions under which the petition is granted constitutes a violation of these rules.

(2) PETITION PROCESSING TIME. Except for priority petitions, the department shall review and make a determination on a petition for variance within 30 business days of receipt of all calculations, documents and fees required to complete the review. The department shall process priority petitions within 10 business days.

Note: Copies of the department petition for variance form SBD 9890 are available from the Division of Safety and Buildings, P.O. Box 7162, Madison, Wisconsin 53707.

(3) DISPROPORTIONALITY IN ALTERED BUILDINGS. When providing a path of travel to an altered area is considered disproportionate, an SBD-10219 form shall be included with the alteration plans submitted for review. The disproportionate costs shall be determined in accordance with the following:

(a) *Disproportional cost.* 1. Alterations made to provide an accessible path of travel to the altered area shall be deemed disproportionate to the overall alteration when the cost exceeds 20% of the cost of the alteration to the primary function area.

2. Costs that may be counted as expenditures required to provide an accessible path of travel may include:

a. Costs associated with providing an accessible entrance and an accessible route to the altered area;

b. Costs associated with making toilet rooms accessible, such as installing grab bars, enlarging toilet stalls, insulating pipes or installing accessible faucet controls;

c. Costs associated with providing accessible telephones, such as relocating the telephone to an accessible height, installing amplification devices or installing a telecommunications device for deaf persons (TDD);

d. Costs associated with relocating an inaccessible drinking fountain.

Note: Copies of the department disproportionality form SBD-10219 are available from the Division of Safety and Buildings, P.O. Box 7162, Madison, Wisconsin 53707.

(b) *Duty to provide accessible features in the event of disproportionality.* 1. When the cost of alterations necessary to make the path of travel to the altered area fully accessible is disproportionate to the cost of the overall alteration, the path of travel shall be made accessible to the extent that it can be made accessible without incurring disproportionate costs.

2. In choosing which accessible elements to provide, priority shall be given to those elements that will provide the greatest access, in the following order:

- a. An accessible entrance;
- b. An accessible route to the altered area;
- c. At least one accessible toilet room for each sex or a single unisex toilet;
- d. Accessible telephones;
- e. Accessible drinking fountains; and
- f. Accessible elements such as parking, storage and alarms.

(c) *Series of alterations.* 1. The obligation to provide an accessible path of travel may not be evaded by performing a series of alterations to the area served by a single path of travel if those alterations could have been performed as a single undertaking.

2. If an area containing a primary function has been altered without providing an accessible path of travel to that area and subsequent alterations of that area, or a different area on the same path of travel, are undertaken within the three years of the original alteration after the effective date of this rule, the total cost of alterations to the primary function areas on that path of travel during the preceding three year period shall be considered in determining whether the cost of making that path of travel accessible is disproportionate.

Unofficial Text (See Printed Volume). Current through date and Register shown on Title Page.

3. Only alterations undertaken after December 1, 1994, shall be considered in determining if the cost of providing an accessible path of travel is disproportionate to the overall cost of the alterations.

History: Cr. Register, November, 1994, No. 467, eff. 12-1-94; r. and recr. (3) (intro.), Register, December, 1997, No. 504, eff. 1-1-98.

Part 6—Adoption of Standards

Comm 69.105 Adoption of standards. (1) CONSENT TO INCORPORATE. Pursuant to s. 227.21, Stats., the attorney general and the revisor of statutes have consented to the incorporation by reference of standards listed in sub. (4).

(2) COPIES. Copies of the adopted standards are on file in the offices of the department, the secretary of state and the revisor of statutes. Copies of the standards may be purchased through the organization listed in sub. (4).

(3) INTERIM AMENDMENTS. Interim amendments of ANSI A156.10-1991 and A156.19-1990 will have no effect in this state until such time as this chapter is correspondingly revised to reflect those changes.

(4) ADOPTION AND AVAILABILITY OF STANDARDS. The following standards are hereby incorporated by reference into this chapter.

(a) The American National Standards Institute (ANSI) A156.10-1991, Power-operated pedestrian doors.

(b) The ANSI A156.19-1990, Power-assist and low-energy, power-operated doors.

Note: Copies of the ANSI A156.10 and A156.19 standards may be obtained from the American National Standards Institute, 11 West 42nd Street, New York, New York 10036.

History: Cr. Register, December, 1997, No. 504, eff. 1-1-98.

Subchapter II — Standards for New Construction, Additions and Alterations**Part 1—ADAAG Standards**

Comm 69.11 Standards for new construction, additions and alterations. (1) ADAAG STANDARDS. Any new construction, addition and alteration subject to this chapter shall comply with the Americans with Disabilities Act Accessibility Guidelines (ADAAG), as printed in Part III of the July 26, 1991 Federal Register and in the September 6, 1991 Federal Register and as corrected in the January 14, 1992 Federal Register, subject to the changes, additions and omissions specified in ss. Comm 69.12 to 69.50.

Note: A reprint of the ADAAG standards is included in Appendix B.

Note: The federal Americans with Disabilities Act (ADA) is a federal law applying to public accommodations and public entities. The ADA law does not preempt the state building code requirements, so an owner is responsible for compliance with the most restrictive requirements from both the federal and state regulations.

Note: Copies of the complete ADA law, preamble and ADAAG standards can be obtained from the Great Lakes Disability and Business Technical Assistance Center, University of Illinois, 1640 West Roosevelt Road, Chicago, Illinois 60608, or New Orders, Superintendent of Documents, P.O. Box 371954, Pittsburgh, Pennsylvania 15250-7954.

(2) DEPARTMENT AUTHORITY. The department shall have the authority and responsibility for interpreting this chapter and the ADAAG standards as reprinted in appendix B. Any changes to the federal ADAAG standards shall not affect the requirements in this chapter until such time as this chapter is correspondingly revised to adopt those changes. A formal interpretation of this chapter shall remain in effect until rescinded or changed or until the code is changed to reflect the new standards.

Note: An owner of a building or facility must comply with all applicable federal, state and local requirements. If the federal ADAAG standards are changed, an owner must comply with those changes at the federal level, even if they are not reflected in this chapter or enforced by the department or its local agents.

History: Cr. Register, November, 1994, No. 467, eff. 12-1-94; r. and recr. (2), Register, December, 1997, No. 504, eff. 1-1-98.

Part 2—Changes or Additions to or Omissions from the ADAAG Standards

Comm 69.12 Changes or additions to or omissions from the ADAAG. Changes or additions to or omissions from the ADAAG standards are specified in this chapter and are rules of the department and are not requirements of the ADAAG standards.

Note: The referenced ADAAG section or rule number, located in the brackets, follows the Comm designation and precedes the text of the rule.

History: Cr. Register, November, 1994, No. 467, eff. 12-1-94.

Subpart 1—Purpose

Comm 69.13 Purpose [ADAAG 1.0]. Substitute the following wording for the first paragraph of ADAAG 1.0: This chapter sets minimum standards for accessibility to a building or facility by an individual with a disability. The requirements of this chapter are to be applied during the design, construction, alteration and occupancy of such a building or facility.

History: Cr. Register, November, 1994, No. 467, eff. 12-1-94.

Subpart 2—General

Comm 69.14 Equivalent facilitation [ADAAG 2.2]. Substitute the following wording for ADAAG 2.2: Departures from particular technical and scoping requirements of this chapter by the use of other designs and technologies are permitted where the alternative designs and technologies used will provide substantially equivalent or greater access to and usability of the building or facility. A petition for variance shall be submitted in accordance with s. Comm 69.10 for alternative designs and technologies.

History: Cr. Register, November, 1994, No. 467, eff. 12-1-94.

Subpart 3—Miscellaneous Instructions and Definitions

Comm 69.15 Miscellaneous instructions and definitions [ADAAG 3.0]. For the purposes of this chapter the following words and terms are defined as:

(1) DEFINITIONS [ADAAG 3.5]. Substitute the following definitions for these definitions found in ADAAG 3.5:

(a) “Access or accessible” means the physical characteristics of a place which allow persons with a functional limitation caused by impairments of sight, hearing, coordination or perception or persons with semiambulatory or nonambulatory disabilities to enter, circulate within and leave a place of employment or public building and to use the public toilet facilities and passenger elevators in the place of employment or public building without assistance.

(b) “Alteration” means a change to a building or facility that affects or could affect the usability of a building or facility or part thereof. An alteration includes, but is not limited to, remodeling, renovation, rehabilitation, reconstruction, historic restoration, changes or rearrangement of the structural parts or elements, and a change or rearrangement in the plan configuration of walls and fixed partitions. Normal maintenance, reroofing, painting or wallpapering, or changes to mechanical and electrical systems are not alterations unless they affect the usability of the building or facility.

(c) “Building” means any structure intended for supporting or sheltering any use or occupancy, including a public building, place of employment, public accommodation, commercial facility, public entity, private entity, private club and a religious organization.

(d) “Facility” means any portion of a building, structure, site improvement, complex, walk, passageway, or parking lot located on a site.

(2) DEFINITIONS [ADAAG 3.5]. These are department definitions in addition to the requirements of ADAAG 3.5:

Unofficial Text (See Printed Volume). Current through date and Register shown on Title Page.

(a) "Appropriate local authority" means the department of industry, labor and human relations or its authorized representative.

(am) "Baptistry" means the area of the church used for baptism.

(ar) "Chancel" means the part of the place of worship containing the altar and seats for the clergy.

(b) "Complying or complies with local requirements" means conforming with any administrative code enforced by this department.

(c) "Disability" means a physical or mental impairment that substantially limits one or more major life activities, a record of having such an impairment or being regarded as having such an impairment.

(cm) "Exit" has the meaning given in s. Comm 51.01 (36a).

Note: Comm 51.01 (36a) reads "exit means that portion of a means of egress which is separated from all other spaces of the building or structure by construction providing a protected way of travel to the exit discharge."

(d) "Fixed partition" means any equipment or divider which serves the same purpose as a full or partial height wall and requiring tools to assemble or disassemble.

(e) "Handgrip portion" means the grasping surface of a handrail to the point where the thumb and fingers curl around and under the rail.

(f) "Path of travel" includes a continuous unobstructed way of pedestrian passage by means of which the altered area may be approached, entered and exited and which connects the altered area with an exterior approach such as sidewalks, streets and parking areas, an entrance to the building or facility and other parts of the building or facility.

(g) "Place of employment" has the meaning given in s. 101.01 (11), Stats.

Note: Section 101.01 (11), Stats., reads "Place of employment" includes every place, whether indoors or out or underground and the premises appurtenant thereto where either temporarily or permanently any industry, trade or business is carried on, or where any process or operation, directly or indirectly related to any industry, trade or business, is carried on, and where any person is, directly or indirectly, employed by another for direct or indirect gain or profit, but does not include any place where persons are employed in a private domestic service which does not involve the use of mechanical power or in farming. "Farming" includes those activities specified in s. 102.04 (3), and also includes the transportation of farm products, supplies or equipment directly to the farm by the operator of said farm or employees for use thereon, if such activities are directly or indirectly for the purpose of producing commodities for market, or as an accessory to such production. When used with relation to building codes, "place of employment" does not include an adult family home certified under s. 50.032 (1) (b) or, except for the purposes of s. 101.11, a previously constructed building used as a community-based residential facility, as defined in s. 50.01 (1g), which serves 20 or fewer unrelated residents.

(h) "Primary function" means a major activity for which a building or facility is intended. Areas that contain a primary function include, but are not limited to, the customer service lobby of a bank, the dining area of a cafeteria, the meeting rooms in a conference center, as well as offices and other work areas in which the activities of the building or facility are carried out. Mechanical rooms, boiler rooms, supply storage rooms, employee lounges or locker rooms, janitorial closets, entrances, corridors and toilet rooms are not areas containing a primary function.

(i) "Professional office of a health care provider" means a location where a person or entity regulated by a State to provide professional services related to the physical or mental health of an individual makes such services available to the public.

(j) "Public building" has the meaning given in s. 101.01 (12), Stats.

Note: Section 101.01 (12), Stats., reads "Public building" means any structure, including exterior parts of such building, such as a porch, exterior platform or steps providing means of ingress or egress, used in whole or in part as place of resort, assemblage, lodging, trade, traffic, occupancy, or use by the public or by 3 or more tenants. When used in relation to building codes, "public building" does not include a previously constructed building used as a community-based residential facility as defined in s. 50.01 (1g) which serves 20 or fewer unrelated residents or an adult family home certified under s. 50.032 (1) (b).

(k) "Remodeling" means to substantially improve, alter, extend or otherwise change the structure of a building or change

the location of exits, but shall not include maintenance, redecoration, reroofing or alteration of mechanical or electrical systems.

(L) "Shopping center or shopping mall" means a building or facility containing 5 or more tenant spaces where at least one space is occupied by a sales or rental establishment. Shopping center or shopping mall includes a building or a series of buildings on a common site, either under common ownership or common control or developed either as one project or as a series of related projects, containing sales or rental establishments. Sales and rental establishments include areas such as bakeries, grocery stores, clothing stores, and hardware stores.

(m) "Specified public transportation" means transportation by bus, rail, or any other conveyance, other than by aircraft, that provides the general public with general or special service, including charter service, on a regular and continuing basis.

History: Cr. Register, November, 1994, No. 467, eff. 12-1-94; cr. (2) (am), (ar) and (cm), Register, December, 1997, No. 504, eff. 1-1-98; corrections in (2) (g) and (j) made under s. 13.93 (2m) (b) 7., Stats., Register, November, 1999, No. 527.

Subpart 4—Accessible Elements and Spaces: Scope and Technical Requirements**Comm 69.16 Applications [ADAAG 4.1.1].**

(1) APPLICATION BASED ON BUILDING USE. [ADAAG 4.1.1 (2)]. These are department rules in addition to the requirements of ADAAG 4.1.1 (2):

(a) *General requirements.* Except as specified in par. (b), buildings or facilities used as places of worship shall comply with s. Comm 69.18, ADAAG 4.1 to 4.35 and all other applicable requirements of this chapter.

(b) *Sanctuary areas.* Sanctuary areas shall be made accessible to persons with disabilities in accordance with the following:

1. An accessible route shall be provided throughout the sanctuary floor area, including choir areas and other similar areas raised or depressed by not more than 3 feet from the accessible floor. Access is not required to the chancel or to baptisteries.

2. Wheelchair seating spaces in assembly areas shall comply with the requirements specified in ADAAG 4.1.3 (19) and ADAAG 4.33.

(2) EQUIPMENT SPACES [ADAAG 4.1.1 (5)]. (a) *Variations [ADAAG 4.1.1 (5) (a)].* This is a department rule in addition to the requirements of ADAAG 4.1.1 (5) (a): Spaces frequented only by service personnel for maintenance, repair, or occasional monitoring of equipment are not required to be accessible. Such spaces include but are not limited to elevator pits, elevator penthouses, mechanical, electrical, or communications equipment rooms, piping or equipment catwalks, water or sewage treatment pump rooms and stations, electric substations and transformer vaults, and highway and tunnel utility facilities.

(b) *General exceptions [ADAAG 4.1.1 (5)].* This is a department rule in addition to the requirements of ADAAG 4.1.1 (5) (b): Variations from the requirements of this chapter may be permitted only through the petition for variance procedures specified in s. Comm 69.10.

History: Cr. Register, November, 1994, No. 467, eff. 12-1-94; r. and recr. Register, December, 1997, No. 504, eff. 1-1-98.

Comm 69.17 Accessible elements and spaces: scope and technical requirements [ADAAG 4.1.2].

(1) PARKING [ADAAG 4.1.2 (5)]. (a) *General parking [ADAAG 4.1.2 (5)].* This is a department rule in addition to the requirements of ADAAG 4.1.2 (5): A vehicle may be parked backwards in an accessible parking space.

Note: Backing into parking spaces accommodates a person transferring from a vehicle by either the passenger or driver side of the vehicle.

(b) *Access aisle [ADAAG 4.1.2 (5) (a) and (b)].* This is a department rule in addition to the requirements of ADAAG 4.1.2 (5) (a) and (b): An access aisle adjacent to an accessible parking space may be identified by a sign or by cross-hatch painting as shown in the ADAAG standards, Appendix A4.6.3, Figure A5.

Unofficial Text (See Printed Volume). Current through date and Register shown on Title Page.

Complete painting of the access aisle and parking space is prohibited.

(c) *Valet parking [ADAAG 4.1.2 (5) (e)].* Substitute the following wording for ADAAG 4.1.2 (5) (e): Valet parking: Where valet parking is offered at a building or facility, the valet parking facility shall be designed in accordance with the following:

1. At least one passenger loading zone complying with ADAAG 4.6.6 shall be located on an accessible route to an accessible entrance of a building or facility.

2. Accessible parking spaces shall be provided at the rate of 2% of the total number of spaces with a minimum of one. The accessible parking spaces shall be located on an accessible route to an accessible entrance to a building or facility.

3. At least one space shall be van accessible as specified in ADAAG 4.1.2 (5) (b).

4. An accessible parking space shall be designated in accordance with sub. (2).

(2) SIGNAGE. [ADAAG 4.1.2 (7)] Substitute the following wording for ADAAG 4.1.2 (7):

(a) *Building signage.* Signs which designate permanent rooms and spaces shall comply with ADAAG 4.30.1, 4.30.4, 4.30.5 and 4.30.6. Other signs which provide direction to, or information about, functional spaces of the building shall comply with ADAAG 4.30.1, 4.30.2, 4.30.3 and 4.30.5. Elements and spaces of accessible facilities which shall be identified by the International Symbol of Accessibility and which shall comply with ADAAG 4.30.7 are:

1. Accessible passenger loading zones;
2. Accessible entrances when not all are accessible. Inaccessible entrances shall have directional signage to indicate the route to the nearest accessible entrance;
3. Accessible toilet and bathing facilities when not all are accessible.

(b) *Parking signage.* When the parking spaces for a building or facility are divided between employee and visitor parking, the accessible parking spaces for the employees may be identified with signs other than the Trans 200.07 sign. The accessible parking spaces for the visitors shall be identified with a sign complying with s. Trans 200.07.

Note: See Appendix A for a reprint of s. Trans 200.07.

History: Cr. Register, November, 1994, No. 467, eff. 12-1-94; am. (1) (c) 2., r. and recd. (2) (b), Register, December, 1997, No. 504, eff. 1-1-98.

Comm 69.18 Accessible buildings: new construction requirements [ADAAG 4.1.3]. **(1) NEW CONSTRUCTION REQUIREMENTS.** Substitute the following wording for ADAAG 4.1.3, intro. paragraph: Except as specified in s. Comm 69.04, all buildings and facilities shall comply with the minimum requirements of ADAAG 4.1.3.

(1m) ACCESSIBLE ROUTE. [ADAAG 4.1.3 (1)] These are department rules in addition to the requirements of ADAAG 4.1.3 (1): An accessible route shall be provided in accordance with the following:

(a) *Accessible floor.* Except as specified in sub. (2), an accessible route shall be provided to at least one accessible floor of a building or facility less than 3 stories and with a gross area of 20,000 square feet or less. The accessible floor shall comply with the following:

1. The accessible floor level shall be a floor where a primary function of the building or facility is carried out for the benefit of the employees or patrons, or both. When common-use areas, including lunchrooms, change rooms, locker rooms or conference rooms, are provided in the building or facility, the accessible floor level shall contain at least one of each type of common-use area. The common-use areas on the accessible floor shall provide comparable services and amenities to the common-use areas provided on inaccessible floors.

2. An accessible route shall be provided throughout the entire accessible floor, including all areas raised or depressed by not more than 3 feet from the accessible floor. Interior accessible routes may include ramps complying with this chapter and ADAAG 4.8 or passenger elevators, limited-use elevators or wheelchair platform lifts complying with this chapter and ch. Comm 18.

(b) *Accessible route to primary function.* The accessible route from the accessible entrances to areas of primary function may serve but shall not pass through kitchens, storage rooms, toilet rooms, bathrooms, closets or other similar spaces.

(2) ELEVATOR ACCESS. [ADAAG 4.1.3 (5)] These are department rules in addition to the requirements of ADAAG 4.1.3 (5):

(a) *Access to all floors.* 1. Except as specified in subd. 2., at least one passenger elevator complying with ADAAG 4.10 shall serve each floor level, including mezzanines, in the following buildings or facilities:

- a. Buildings and facilities 3 stories or greater in height where at least one story contains 3,000 square feet or more.
- b. Government-owned or operated facilities.
- c. Shopping centers or shopping malls.
- d. Professional offices of a health care provider.
- e. Transportation facilities.

2. Elevator access is not required to the following:

a. Unoccupied floor levels used for the storage of goods, merchandise, products or wares. The storage floor level may not be used as a permanent workstation for any employee, as a common-use area for employees, or by the public for any reason. If the use of the storage floor level changes to that of an occupied space, a passenger elevator complying with this chapter and ch. Comm 18 shall be installed to provide an accessible route of travel between the floor levels.

b. Floor levels with additional residential detention cells, if the accessible residential detention cells comply with s. Comm 69.49 (2).

c. Government-owned or operated buildings or facilities that are less than three stories and that are not open to the general public, if the story above or below the accessible ground floor has a capacity of no more than five persons and is less than 500 square feet. The story above or below the accessible ground floor that is less than 500 square feet shall have a sign stating the maximum capacity and the sign shall be placed in a conspicuous location at the main entrance to the floor level.

Note: Examples may include, but are not limited to, drawbridge towers and boat traffic towers, lock and dam control stations, press boxes, and train dispatching towers.

(b) *Gross area greater than 20,000 square feet.* 1. Except as specified in subds. 2. and 3., one passenger elevator, limited-use elevator, wheelchair platform lift or ramp shall serve each floor level, including mezzanines, in all buildings or facilities with a gross area greater than 20,000 square feet.

2. Access is not required to the following:

- a. Mezzanines with additional employment areas.
- b. Mezzanines with common-use areas where the common-use areas are comparable to those provided on an accessible floor level.
- c. Floor levels with additional sleeping rooms in transient lodging buildings or facilities, if the building or facility complies with this chapter and ADAAG 9.1.1 to 9.4.

d. Unoccupied floor levels used for the storage of goods, merchandise, products or wares. The storage floor level may not be used as a permanent workstation for any employee, as a common-use area for employees, or by the public for any reason. If the use of the storage floor level changes to that of an occupied space, an accessible route of travel between floor levels shall be provided in accordance with this subsection.

Unofficial Text (See Printed Volume). Current through date and Register shown on Title Page.

3. Elevators complying with ADAAG 4.10 shall serve each floor level in buildings and facilities as specified in par. (a).

(3) AREAS OF RESCUE ASSISTANCE [ADAAG 4.1.3 (9)]. (a) *General [ADAAG 4.1.3 (9)].* This is a department informational note to be used under ADAAG 4.1.3 (9):

Note: See s. Comm 69.15 (2) (cm) for definition of exit.

(b) *Exception [ADAAG 4.1.3 (9) EXCEPTION].* This is a department rule in addition to the requirements of ADAAG 4.1.3 (9) Exception: Areas of rescue assistance are not required at exits from unoccupied floor levels used for storage as specified in sub. (2) (a) 2. a. and (b) 2. d.

(4) TOILET FACILITIES. [ADAAG 4.1.3 (11)] This is a department rule in addition to the requirements of ADAAG 4.1.3 (11): Other toilet rooms provided for the use of occupants of specific spaces including a private toilet room for the occupant of a private office shall be sized in accordance with ADAAG 4.22 and shall be provided with solid blocking in the walls for the later installation of grab bars.

History: Cr. Register, November, 1994, No. 467, eff. 12-1-94; r. and recr. Register, December, 1997, No. 504, eff. 1-1-98; emerg. cr. (2) (a) 2. c., eff. 5-14-98; cr. (2) (a) 2. c., Register, December, 1998, No. 516, eff. 1-1-99.

Comm 69.19 Accessible building: additions [ADAAG 4.1.5]. Substitute the following wording for ADAAG 4.1.5:

(1) SPACES AND ELEMENTS. (a) Except as specified in sub. (2) (a), each space or element added to an existing building or facility shall comply with the applicable provisions of this chapter, ADAAG 4.1.1 to 4.1.3, minimum requirements for new construction, and the applicable technical specifications of ADAAG 4.2 to 4.35 and sections 5 through 10.

(2) ADDITIONS AS ALTERATIONS. (a) Where an addition to an existing building or facility is constructed only to enclose an elevator, limited-use elevator or vertical wheelchair platform lift, the construction shall be considered an alteration.

(b) Each addition that affects or could affect the usability of an area containing a primary function shall comply with ADAAG 4.1.6 (2).

History: Cr. Register, November, 1994, No. 467, eff. 12-1-94; r. and recr. Register, December, 1997, No. 504, eff. 1-1-98.

Comm 69.20 Accessible buildings: alterations [ADAAG 4.1.6]. **(1) EXCEPTIONS.** [ADAAG 4.1.6 (1) (k) (i)] This is a department rule in addition to the requirements of ADAAG 4.1.6 (1) (k) (i): An accessible route between floor levels shall be provided in an existing building or facility in accordance with s. Comm 69.18 and ADAAG 4.1.3, unless providing the path of travel is disproportionate as specified in s. Comm 69.10.

(2) ALTERATIONS TO AN AREA CONTAINING A PRIMARY FUNCTION. [ADAAG 4.1.6 (2)] These are department rules in addition to the requirements of ADAAG 4.1.6 (2): When providing a path of travel to an altered area is considered disproportionate to the overall alterations in terms of cost and scope, a SBD-10219 form shall be submitted along with the construction plans justifying the disproportionality.

(3) SPECIAL TECHNICAL PROVISIONS FOR ALTERATION TO EXISTING BUILDINGS AND FACILITIES [ADAAG 4.1.6 (3)]. (a) *Toilet rooms [ADAAG 4.1.6 (3) (e)].* This is a department rule in addition to ADAAG 4.1.6 (3) (e) (i): A unisex toilet room shall be designed in accordance with s. Comm 69.35 (1).

(b) *Platform lifts [ADAAG 4.1.6 (3) (g)].* These are department rules in addition to the requirements of ADAAG 4.1.6.(3) (g):

1. Limited-use elevators or vertical or inclined wheelchair lifts complying with ch. Comm 18 may be used as part of an accessible route. The accessible route shall be clearly designated and maintained.

Note: A limited-use elevator as used in this chapter does not qualify as a full passenger elevator complying with ADAAG 4.10 or the ASME A17.1 Elevator Code,

but it exceeds the requirements of a vertical or inclined wheelchair lift. A limited-use elevator may be used in lieu of a vertical or inclined wheelchair lift.

2. Stairway chairlifts are not acceptable as meeting the accessibility requirements of this chapter. Stairway chairlifts installed in buildings or facilities for other purposes shall comply with ch. Comm 18 and the applicable portions of chs. Comm 50 to 64.

3. Residential elevators complying with A17.1 Part 5 and ch. Comm 18 may only be installed in places of worship built prior to April 1, 1994.

History: Cr. Register, November, 1994, No. 467, eff. 12-1-94; r. and recr. Register, December, 1997, No. 504, eff. 1-1-98; r. and recr. (3) (b) 3., Register, November, 1999, No. 527, eff. 12-1-99.

Comm 69.21 Accessible buildings: historic [ADAAG 4.1.7]. Substitute the following wording for ADAAG 4.1.7 (1) (b): A qualified historic building means a building or facility complying with the definition specified in s. Comm 70.02 (1).

History: Cr. Register, November, 1994, No. 467, eff. 12-1-94; r. and recr. Register, December, 1997, No. 504, eff. 1-1-98.

Comm 69.22 Wheelchair passage width [ADAAG 4.2.1]. This is a department rule in addition to the requirements of ADAAG 4.2.1: The width of an exit passageway shall comply with the applicable occupancy requirements in chs. Comm 50 to 64.

History: Cr. Register, November, 1994, No. 467, eff. 12-1-94.

Comm 69.23 Accessible route [ADAAG 4.3]. **(1) WIDTH [ADAAG 4.3.3].** This is a department rule in addition to the requirements of ADAAG 4.3.3: Figures 7 (a) and 7. (b) shall not apply to ramp designs.

(2) SLOPE [ADAAG 4.3.7]. This is a department rule in addition to the requirements of ADAAG 4.3.7: Handrails, curbs or other forms of protection shall be provided on the sides of an accessible route where the adjacent terrain exceeds a 25%, 1:4, downward slope away from the accessible route.

(3) LOCATION AND CONSTRUCTION [ADAAG 4.3.11.1]. Substitute the following wording for ADAAG 4.3.11.1: An area of rescue assistance shall be one of the following:

(a) A portion of a balcony to or a stairway landing within a smokeproof stair tower meeting the fire-rated enclosure requirements as specified in s. Comm 51.17;

(b) A portion of a landing of an exterior exit stairway. Any opening to the interior of the building located within 20 feet of the area of rescue assistance shall be protected with a fire door or window assembly having a 3/4-hour fire protection rating;

(c) A portion of a corridor meeting the fire-rated enclosure requirements as specified in Table 51.03-A. The area of rescue assistance shall be immediately adjacent to a stairway enclosure meeting the fire-rated construction as specified in s. Comm 51.02 (1);

(d) A vestibule located immediately adjacent to an exit enclosure and constructed to the same fire-resistive standards as required for corridors and openings;

(e) A portion of a landing within a stairway enclosure which is vented to the exterior and is separated from the interior of the building with fire-rated construction as specified in s. Comm 51.02 (11);

(f) A smoke-barrier provided in a health care facility as specified in ch. Comm 58, subch. I; or

(g) A horizontal exit as specified in s. Comm 51.19.

History: Cr. Register, November, 1994, No. 467, eff. 12-1-94.

Comm 69.24 Protruding objects [ADAAG 4.4.1]. **(1) GENERAL, OBJECTS AT CORNER.** These are department rules in addition to ADAAG 4.4.1: A protruding object such as, but not limited to, a telephone, water cooler, or planter shall be installed not less than 36 inches from any corridor wall corners.

(2) GENERAL, CLEAR WIDTH. Substitute the following wording for the last sentence of ADAAG 4.4.1: A protruding object shall

Unofficial Text (See Printed Volume). Current through date and Register shown on Title Page.

not reduce the clear width of an accessible route, maneuvering space or the required exit width as specified in chs. Comm 50 to 64.

History: Cr. Register, November, 1994, No. 467, eff. 12-1-94.

Comm 69.245 Parking spaces [ADAAG 4.6.3]. These are department rules in addition to the requirements of ADAAG 4.6.3:

(1) **PARKING ACCESS AISLE AND ACCESSIBLE ROUTE.** Except as specified in sub. (2), a parking access aisle shall lead to an accessible route. The accessible route shall comply with all of the following:

- (a) Lead to an accessible building entrance.
- (b) Not be located within the traffic lanes, except as permitted in par. (c).
- (c) Cross the flow of traffic only at marked crossings.
- (d) Be protected by physical barriers, including wheel stops, curbs or bollards, when located between rows of parking spaces or when located between parking spaces and a building.

(2) **EXEMPTION.** Where it is technically infeasible to redesign an existing parking lot to provide an accessible route complying with sub. (1), an accessible route may be located within a traffic lane providing the accessible route leads to an accessible building entrance or to a marked crossing leading to an accessible building entrance.

Note: See Appendix A for examples of parking access aisles and accessible routes.

History: Cr. Register, December, 1997, No. 504, eff. 1-1-98.

Comm 69.25 Curb ramps [ADAAG 4.7]. (1) WIDTH [ADAAG 4.7.3]. Substitute the following wording for ADAAG 4.7.3: The minimum width of a curb ramp shall be 40 inches, exclusive of flared sides.

(2) **SURFACE [ADAAG 4.7.4].** Substitute the following wording for ADAAG 4.7.4: The surface of a curb ramp, excluding the flared sides, shall comply with ADAAG 4.5 and s. Comm 69.37.

History: Cr. Register, November, 1994, No. 467, eff. 12-1-94.

Comm 69.26 Ramps [ADAAG 4.8]. (1) CLEAR WIDTH. [ADAAG 4.8.3] Substitute the following wording for ADAAG 4.8.3:

(a) *Exterior ramps.* The minimum clear width of a ramp shall be 40 inches, measured between the handrails.

(b) *Interior ramps.* The minimum clear width of an interior ramp shall be 36 inches, measured between the handrails.

(2) **LANDINGS. [ADAAG 4.8.4]** This is a department informational note to be used under ADAAG 4.8.4:

Note: See s. Comm 51.162 for guardrail requirements.

History: Cr. Register, November, 1994, No. 467, eff. 12-1-94; r. and recr. (2), Register, December, 1997, No. 504, eff. 1-1-98.

Comm 69.27 Stairs [ADAAG 4.9]. (1) RISER AND TREAD [ADAAG 4.9.2]. This is a department rule in addition to the requirements of ADAAG 4.9.2: On any given flight of stairs, all steps shall have uniform riser heights and uniform tread widths. Maximum riser height shall be 7 inches and the minimum riser height shall be 4 inches. Minimum tread depth shall be 11 inches measured horizontally between the vertical planes of the foremost projection of adjacent treads and at a right angle to the tread's leading edge. Open risers are not permitted.

(2) **HANDRAILS [ADAAG 4.9.4].** This is a department informational note to be used under ADAAG 4.9.4:

Note: See s. Comm 51.161 (6) for requirements for handrails at stairways.

History: Cr. Register, November, 1994, No. 467, eff. 12-1-94; r. and recr. (2), Register, December, 1997, No. 504, eff. 1-1-98.

Comm 69.275 Elevators [ADAAG 4.10]. (1) HANDRAILS. This is a department rule in addition to the requirements of ADAAG 4.10: Each elevator car shall have a handrail mounted on the back or side wall of the car. The top of the handrail shall

be mounted between 34 to 38 inches above the car floor. The space between the handrail and the wall shall be 1-1/2 inches.

(2) **HALL CALL BUTTONS. [ADAAG 4.10.3]** Substitute the following wording for ADAAG 4.10.3: Call buttons in elevator lobbies and halls shall be 35 inches minimum and 48 inches maximum above the floor or ground, measured to the centerline of the buttons. A clear floor space or ground space complying with ch. Comm 69, ADAAG 4.2.4 that allows for a forward or parallel approach shall be provided at the hall call button. Such call buttons shall have visual signals to indicate when each call is registered and when each call is answered. Call buttons shall be 3/4 inch minimum in their smallest dimension, and shall be raised or flush. The button that designates the up direction shall be above the button that designates the down direction. Objects mounted beneath hall call buttons shall not project into the elevator lobby more than 4 inches.

History: Cr. Register, December, 1997, No. 504, eff. 1-1-98; r. and recr. Register, November, 1999, No. 527, eff. 12-1-99.

Comm 69.28 Platform lifts [ADAAG 4.11]. Substitute the following wording for ADAAG 4.11.2: If limited-use elevators, vertical or inclined platform lifts, stairway chairlifts or residential elevators are installed in a building or facility as permitted in this chapter, they shall comply with ADAAG 4.2.4, 4.5, and 4.27 and ch. Comm 18.

History: Cr. Register, November, 1994, No. 467, eff. 12-1-94; r. and recr. Register, December, 1997, No. 504, eff. 1-1-98; r. and recr. Register, November, 1999, No. 527, eff. 12-1-99.

Comm 69.29 Doors [ADAAG 4.13]. (1) MANEUVERING CLEARANCES AT DOORS. [ADAAG 4.13.6] This is a department rule in addition to the requirements of ADAAG 4.13.6: A door recessed more than 8 inches, measured from the face of the door to the face of the wall, shall be considered a door in an alcove and the maneuverability clearances shown in Figure 25 (a) shall be provided.

Note: See ss. Comm 18.41 and 18.74 for maneuvering clearances at A17.1 Part 5 elevators and A17.1 Part 20 wheelchair lifts.

(2) **TWO DOORS IN SERIES. [ADAAG 4.13.7]** This is a department rule in addition to the requirements of ADAAG 4.13.7: Doors with a screen door or storm door shall be considered doors in series and shall comply with ADAAG 4.13.7.

Note: See Appendix A for examples of doors in series.

(3) **AUTOMATIC DOORS AND POWER-ASSISTED DOORS. [ADAAG 4.13.12]** Substitute the following wording for ADAAG 4.13.12: If an automatic door is used, then it shall comply with ANSI/BHMA A156.10-1991. Slowly opening, low-powered, automatic doors shall comply with ANSI A156.19-1990. Such doors shall not open to back check faster than 3 seconds and shall require no more than 15 pounds of force to stop door movement. If a power-assisted door is used, its door-opening force shall comply with ADAAG 4.13.11 and its closing shall conform to the requirements in ANSI A156.19-1990.

History: Cr. Register, November, 1994, No. 467, eff. 12-1-94; r. and recr. Register, December, 1997, No. 504, eff. 1-1-98.

Comm 69.30 Toilet stalls [ADAAG 4.17]. (1) SIZE AND ARRANGEMENT. [ADAAG 4.17.3] Substitute the following wording for the exception under ADAAG 4.17.3: In instances of alteration work where a standard stall [Fig. 30 (a)] is not structurally possible or where the number of sanitary fixtures required by chs. Comm 50 to 64 prevent combining existing stalls to provide space, the following stalls may be used in lieu of the standard stall:

(a) A toilet stall measuring 36 inches in width by 78 inches in length. The toilet stall shall have an outswinging door located at the end of the stall and the door opening shall provide a minimum of 32 inches of clear opening;

(b) A toilet stall measuring at least 36 inches in width by at least 90 inches in length. The toilet stall shall have an outswinging door located at the side of the stall and the door be at least 36 inches in

Unofficial Text (See Printed Volume). Current through date and Register shown on Title Page.

width and shall provide a minimum clear opening specified in ADAAG 4.1.6 (3) (d); or

(c) A toilet stall measuring at least 48 inches in width by at least 69 inches in length. The toilet stall shall have an outswinging stall door located at the end of the stall. The toilet stall door shall provide a minimum of 32 inches of clear opening. The water closet shall be offset as shown in ADAAG 4.17.3, Fig. 30 (b) the bottom diagram.

(2) DOORS [ADAAG 4.17.5]. This is a department rule in addition to the requirements of ADAAG 4.17.5: A toilet stall door shall open at least 95 degrees and shall be self-closing by gravity.

History: Cr. Register, November, 1994, No. 467, eff. 12-1-94; renum. (1) and (2) to be (2) and (1) and am. (1) (c), r. and recr. (1) (b), Register, December, 1997, No. 504, eff. 1-1-98.

Comm 69.32 Faucets [ADAAG 4.19.5]. This is a department rule in addition to the requirements of ADAAG 4.19.5: A foot-controlled faucet is prohibited for use on an accessible lavatory.

History: Cr. Register, November, 1994, No. 467, eff. 12-1-94.

Comm 69.34 Shower stalls [ADAAG 4.21]. (1) SIZE AND CLEARANCES [ADAAG 4.21.2]. This is a department rule in

addition to the requirements of ADAAG 4.21.2: The shower stall in ADAAG Figure 35 (a) shall be 36 inches by 36 inches, measured from inside wall to inside wall.

(3) SHOWER ENCLOSURES [ADAAG 4.21.8]. This is a department rule in addition to the requirements of ADAAG 4.21.8: A swing-door is prohibited on an accessible shower stall.

History: Cr. Register, November, 1994, No. 467, eff. 12-1-94; r. (2), Register, December, 1997, No. 504, eff. 1-1-98.

Comm 69.35 Toilet rooms, clear floor space [ADAAG 4.22.3]. (1) TOILET ROOMS. This is a department rule in addition to the requirements of ADAAG 4.22: A toilet room containing one water closet and one lavatory shall be designed to provide the minimum space requirements as shown in Figure 69.35-1 to 69.35-5 or as approved by the department.

Note: These room dimensions were derived using a lavatory with a maximum width of 19 inches. If a lavatory with a wider dimension is used, the room width would need to be increased.

(2) CLEAR FLOOR SPACE. This is a department rule in addition to the requirements of ADAAG 4.22.3: In a toilet room containing a tub, water closet and lavatory, the water closet shall not infringe on the clear floor space specified in ADAAG 4.20.3, Figure 33.

History: Cr. Register, November, 1994, No. 467, eff. 12-1-94; r. and recr. (2), Register, December, 1997, No. 504, eff. 1-1-98.

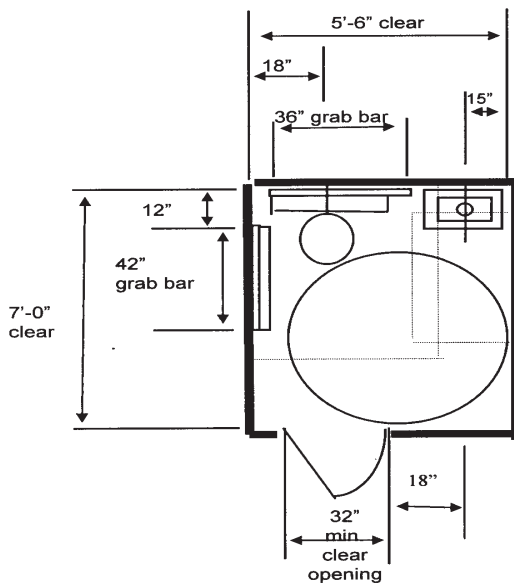

Figure 69.35-1/Toilet Room

Clear floor space at fixtures
 48" by 66" at water closet
 30" by 48" at lavatory

 60" diameter turning space

Unofficial Text (See Printed Volume). Current through date and Register shown on Title Page.

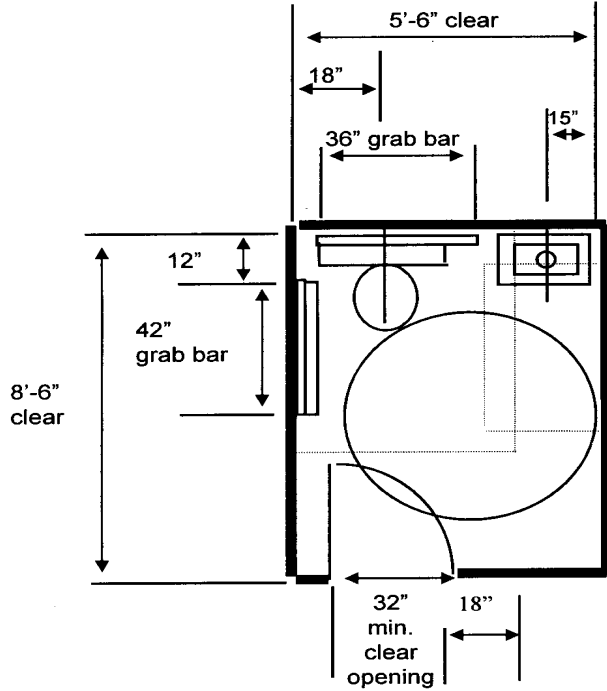

Figure 69.35-2/Toilet Room

Clear floor space at fixtures
 48" by 66" at water closet
 30" by 48" at lavatory

 60" diameter turning space

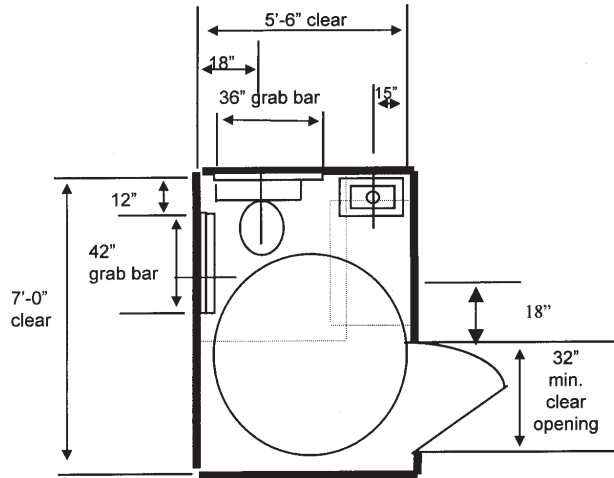

Figure 69.35-3/Toilet Room

Clear floor space at fixtures
 48" by 56" at water closet
 30" by 48" at lavatory

 60" diameter turning space

Unofficial Text (See Printed Volume). Current through date and Register shown on Title Page.

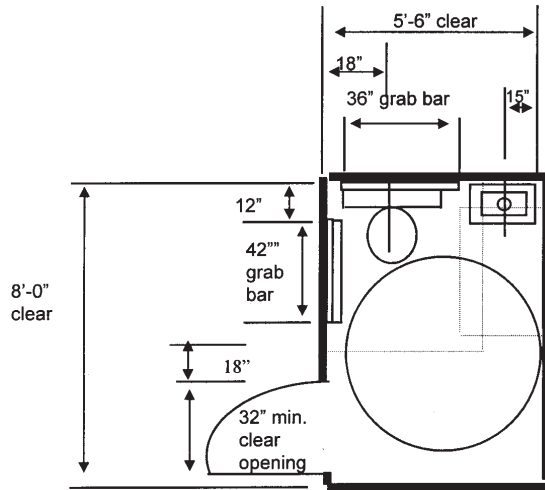

Figure 69.35-4/Toilet Room

Clear floor space at fixtures
 48" by 56" at water closet
 30" by 48" at lavatory
 60" diameter turning space

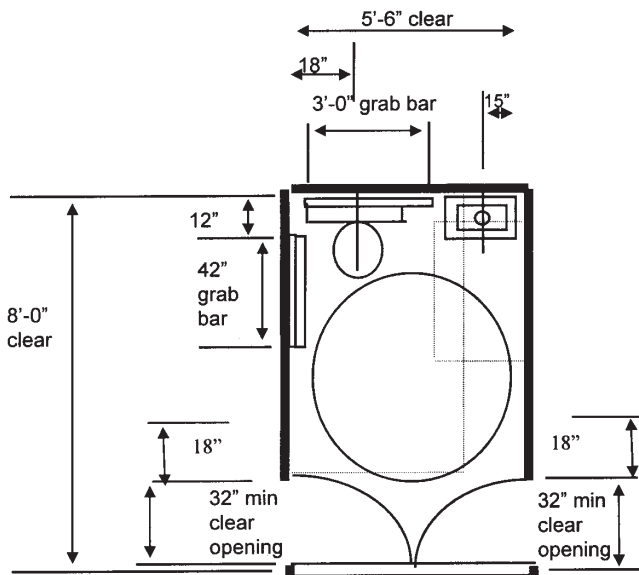

Figure 69.35-5/Toilet Room

Clear floor space at fixtures
 48" by 56" at water closet
 30" by 48" at lavatory
 60" diameter turning space

Unofficial Text (See Printed Volume). Current through date and Register shown on Title Page.

Comm 69.36 Size and spacing of grab bars and handrails [ADAAG 4.26.2]. Substitute the following wording for ADAAG 4.26.2:

(1) **HANDRAIL OR GRAB BAR SIZE.** [ADAAG 4.26.2] This is a department rule in addition to the requirements of ADAAG 4.26.2: The handgrip portion of handrails shall have a smooth surface with no sharp corners. Handrails as shown in ADAAG Figure 39 (b) and (c) are not acceptable for stairways or ramps required to comply with s. Comm 51.16.

(2) **HANDGRIP PORTION.** The handgrip portion of a handrail shall be graspable along the entire length of the handrail.

(3) **MOUNTING ADJACENT TO WALLS.** If a handrail is mounted adjacent to the wall, the space between the wall and the handrail shall be 1-1/2 inches. A handrail may be located in a recess if the recess is a maximum of 3 inches deep and extends at least 18 inches above the top of the rail as shown in ADAAG Figure 39 (d).

History: Cr. Register, November, 1994, No. 467, eff. 12-1-94; r. and recr. (1), Register, December, 1997, No. 504, eff. 1-1-98.

Comm 69.37 Detectable warnings on walking surfaces [ADAAG 4.29.2]. Substitute the following wording for the requirements of ADAAG 4.29.2:

(1) **SURFACE TEXTURING.** Surface texturing shall consist of linear impressions one-fourth of an inch to three-eighths of an inch deep, oriented to provide a uniform pattern of diamond shapes. The diamond shape shall measure approximately 1-1/4 inches wide by 2-1/4 inches long, with the length of the diamond shape parallel to direction of pedestrian movement. The diamond shape shall be spaced one-fourth of an inch to three-eighths of an inch apart. This surface texture may be achieved by impressing and removing expanded metal regular industrial mesh into the surface of the ramp while the concrete is in a plastic state.

(2) **INTERIOR SURFACES.** Detectable warnings used on interior surfaces shall differ from adjoining walking surfaces in resiliency or sound-on-cane contact.

History: Cr. Register, November, 1994, No. 467, eff. 12-1-94.

Comm 69.375 Assembly seating [ADAAG 4.33.3]. This is a department rule in addition to the requirements of ADAAG 4.33.3, Exception: The clustered seating specified for bleachers, balconies and other areas having sight lines that require slopes of greater than 5% shall be located on an accessible route and integrated within the assembly seating.

History: Cr. Register, December, 1997, No. 504, eff. 1-1-98.

Comm 69.39 Dressing and fitting rooms [ADAAG 4.35]. (1) **GENERAL** [ADAAG 4.35.1]. This rule is a department rule in addition to the requirements of ADAAG 4.35.1: A dressing or fitting room shall be designed to provide the minimum space requirements as shown in Figure 69.39, or as approved by the department.

(2) **CLEAR FLOOR SPACE** [ADAAG 4.35.2]. Modify ADAAG 4.35.2 by eliminating the last sentence.

Figure 69.39
MINIMUM SIZE OF DRESSING AND FITTING ROOMS

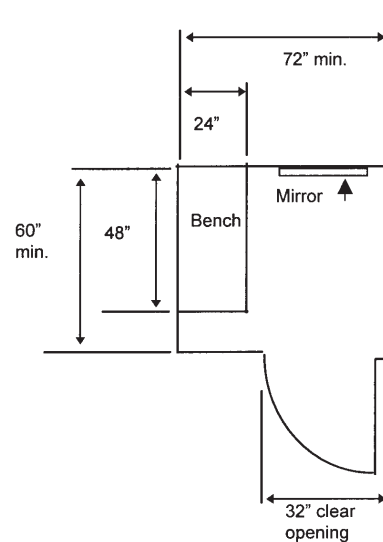

History: Cr. Register, November, 1994, No. 467, eff. 12-1-94.

Subpart 5—Restaurants and Cafeterias

Comm 69.40 Restaurants and cafeterias [ADAAG 5.0]. (1) **GENERAL** [ADAAG 5.1]. These are department rules in addition to the requirements of ADAAG 5.1:

(a) The requirements in this section apply to taverns and any other type of eating or drinking establishments.

(b) At least 5% of all types of seating shall be accessible. The accessible seating shall be integrated throughout the seating areas and shall comply with ADAAG 4.32.

(2) **DINING AREAS** [ADAAG 5.4]. This is a department rule in addition to the requirements of ADAAG 5.4: Any area raised or depressed by not more than 3 feet from the principal floor level shall be ramped in accordance with ADAAG 4.8.

History: Cr. Register, November, 1994, No. 467, eff. 12-1-94.

Subpart 6—Medical Care Facilities

Comm 69.41 Medical care facilities [ADAAG 6.0]. Substitute the following wording for ADAAG 6.1 (1): At least 10% of patient bedrooms and toilet rooms, but not less than one bedroom and toilet room shall be available to patients regardless of the unit of care that they are assigned to or type of treatment they are receiving, and all public use and common use areas shall be designed and constructed to be accessible.

History: Cr. Register, November, 1994, No. 467, eff. 12-1-94.

Subpart 7—Business and Mercantile

Comm 69.415 General [ADAAG 7.1]. Substitute the following wording for ADAAG 7.1:

(1) **AREAS USED FOR BUSINESS TRANSACTIONS.** In addition to the requirements of ADAAG 4.1 to 4.35, the design of all areas used for business transactions with the public shall comply with ADAAG 7.

(2) **MINI-STORAGE BUILDINGS.** At least 5% of mini-storage buildings, with a minimum of one of each type of storage area, shall be accessible. The entrances to the accessible storage units shall comply with ADAAG 4.13. The accessible entrances shall

Unofficial Text (See Printed Volume). Current through date and Register shown on Title Page.

be on an accessible route complying with ADAAG 4.5. The accessible route is not required to be paved.

History: Cr. Register, December, 1997, No., 504, eff. 1-1-98.

Subpart 8—Libraries

Note: There are no changes, additions or omissions to ADAAG 8.0, Libraries.

Subpart 9—Accessible Transient Lodging

Comm 69.42 Accessible transient lodging [ADAAG 9.0]. Substitute the following wording for ADAAG 9.1.2: Accessible sleeping rooms or suites that comply with the requirements of ADAAG 9.2 shall be provided in conformance with Table 69.42. In addition, in hotels of 50 or more sleeping rooms or suites, additional accessible sleeping rooms or suites that include a roll-in shower shall also be provided in conformance with Table 69.42. Rooms with accessible shower stalls shall comply with the requirements of ADAAG 9.2, 4.21 and Figure 57 (a) or (b).

TABLE 69.42

Number of Rooms	Accessible Rooms	Rooms with Roll-in Showers
0 to 50	5% of total with min. of 1	
51 to 100	5% of total	1
101 to 200	5% of total	2
201 to 300	5% of total	3
301 to 400	5% of total	4
401 to 500	5% of total	4 plus 1 for each additional 100 over 400
501 and over	25 plus 1 for each 100 over 500	

History: Cr. Register, November, 1994, No. 467, eff. 12-1-94; r. and recr. Register, December, 1997, No. 504, eff. 1-1-98.

Subpart 10—Transportation Facilities

Note: There are no changes, additions or omissions to ADAAG 10.0, Transportation Facilities.

Subpart 11—Judicial, Legislative, and Regulatory Facilities

Comm 69.45 General. Except as specified in s. Comm 69.04 (10), all judicial, legislative and regulatory facilities shall comply with the applicable requirements specified in ADAAG 4.1 to 4.35. All public and common use areas shall be designed and constructed to comply with ADAAG section 4.

History: Cr. Register, November, 1994, No. 467, eff. 12-1-94.

Subpart 12—Detention and Correctional Facilities

Comm 69.46 General. This subpart applies to jails, holding cells in police stations, prisons, juvenile detention centers, reformatories, and other institutional occupancies where the occupants are under some degree of restraint or restriction for security reasons. Except as specified in this subpart, detention and correctional facilities shall comply with the applicable requirements of ADAAG 4.1 through 4.35. All public and common use areas serving accessible cells or rooms are required to be designed and constructed to comply with ADAAG section 4.

History: Cr. Register, November, 1994, No. 467, eff. 12-1-94.

Comm 69.47 Entrances. (1) SECURED ENTRANCES. Where provided, at least one secured entrance shall comply with ADAAG 4.14. This requirement is in addition to the entrances that are required to be accessible by ADAAG 4.1.3 (8). A secured entrance is an entrance used only by inmates or detainees and security personnel and not the general public.

(2) SECURITY SYSTEMS. Where security systems are provided at public entrances required to be accessible by ADAAG 4.1.3 (8),

an accessible route complying with ADAAG 4.3 shall be provided through fixed security barriers. Where security barriers incorporate equipment such as metal detectors, fluoroscopes, or other similar devices which cannot be made accessible, an accessible route shall be provided adjacent to the security screening devices to facilitate an equivalent path of travel.

History: Cr. Register, November, 1994, No. 467, eff. 12-1-94.

Comm 69.48 Residential cells or rooms: minimum number. (1) RESIDENTIAL CELLS OR ROOMS. At least 5% of the total number of residential cells or rooms, but not less than one of each type of cell or room, shall be accessible and comply with s. Comm 69.49.

(2) ALTERATIONS TO CELLS OR ROOMS. When residential cells or rooms are being altered in an existing facility, at least 5% of the number being altered shall be made accessible until the number of accessible residential cells or rooms equals the total number of accessible residential cells or rooms required for the facility.

History: Cr. Register, November, 1994, No. 467, eff. 12-1-94.

Comm 69.49 Requirements for accessible residential cells or rooms. (1) GENERAL. Cells or rooms required to [be] accessible by s. Comm 69.48 shall comply with this section.

(2) MINIMUM REQUIREMENTS. An accessible residential cell or room shall be on an accessible route complying with ADAAG 4.3. Where provided, the following elements or spaces serving accessible residential cells or rooms shall be accessible and connected by an accessible route. At least one of each type of common area, amenity, space, or element provided for another residential cell or room in the same category of housing shall be accessible. Vertical circulation between residential cell rooms in detention facilities is not required if all the accessible cells are located on an accessible floor level.

(a) Doors and doorways. All doors and doorways on an accessible route shall comply with ADAAG 4.13.

(b) Restrooms. At least one toilet facility shall comply with ADAAG 4.22 and one bathing facility shall comply with ADAAG 4.23. Where privacy screens are provided, they shall not intrude on the clear floor space required for fixtures and accessible route.

(c) Beds. A bed shall have a minimum 36 inches of clear width maneuvering space located along one side of the bed. Where more than one bed is provided in a room or cell, the clear space provided at adjacent beds may overlap.

(d) Drinking fountains and water coolers. Where provided, there shall be a drinking fountain accessible to an individual who uses a wheelchair in accordance with ADAAG 4.15 and one drinking fountain accessible to an individual who has difficulty bending or stooping.

(e) Fixed or built-in seating or tables. Fixed or built-in seating or tables within, or serving, accessible cells or rooms shall comply with ADAAG 4.1.3 (18).

(f) Fixed benches. A fixed bench shall be a minimum of 24 inches by 48 inches and be mounted at 17 to 19 inches above the finish floor. The structural strength of the bench attachments shall comply with ADAAG 4.26.3.

(g) Storage. At least one of each type of fixed or built-in storage facility provided, such as a cabinet, shelf, closet, or drawer shall contain storage space complying with ADAAG 4.25. Additional storage may be provided outside of the dimensions required by ADAAG 4.25.

(h) Controls. Any control intended for operation by an inmate shall comply with ADAAG 4.27.

(i) Room accommodations, hearing impaired. Room accommodations for persons with hearing impairments shall comply with s. Comm 69.50.

History: Cr. Register, November, 1994, No. 467, eff. 12-1-94.

Comm 69.50 Visual alarms and telephones. (1) GENERAL. An auxiliary visual alarm complying with

Unofficial Text (See Printed Volume). Current through date and Register shown on Title Page.

ADAAG 4.28.4 shall be provided in a residential cell or room which is served by an audible emergency warning system and which houses an inmate or detainee who is allowed an independent means of egress. A permanently installed telephone shall have a volume control complying with ADAAG 4.31.5.

(2) EQUIVALENT FACILITATION. For purposes of this section, equivalent facilitation shall include the installation of electrical outlets, including outlets connected to a facility's central alarm system, and telephone wiring in the cell or room to enable inmates or detainees with hearing impairments to utilize portable visual alarms and communication devices made available by the operator of the facility.

History: Cr. Register, November, 1994, No. 467, eff. 12-1-94.